

## Model Pro221P Zoning Panel

These zoning panels offer many features that simplify installation in RNC and AOR installations.

- Panel automatically controls bypass and eliminates installers having to set and test bypass.
- Use an external modulating bypass damper or use the non-calling zone dampers for bypass.
- A2L Refrigerant Leak monitor opens all dampers when equipment indicates a leak occurred.
- On panel display for selecting options and monitoring operation.
- Cloning multiple panels to the same configuration simplifies installation and eliminates errors.
- Works with single stage Heat Pumps with O or B reversing valve and single stage auxiliary heat.
- Works with Heat/Cool and Heat Pump thermostats with emergency heat control.
- Eliminates expensive, add-on Bypass controls.
- These zoning panels provide superior operation, easier installation and lower cost than competitive panels.



Patent Pending

## Features

### Zoning Panel for GE and Heat Pumps

Model	Zones	Gas/Electric	Heat Pump
Pro332P	3	2H/2C	2Compressor/1Aux
Pro311P	3	1H/1C	NA
Pro211P	2	1H/1C	NA
Pro321P	3	NA	1Compressor/1Aux
Pro221P	2	NA	1Compressor/1Aux

### Compatible Zone Thermostats

A heat/cool or heat pump thermostat can be used in Zone1. Use a heat/cool thermostat in Zone2.

### Zone Dampers

Zone dampers are plug&play with modulating actuators. 25' Cables provided with dampers.

### A2L Leak Monitor

Opens dampers when equipment indicates a leak has been detected.

### Automatic Bypass Control

The panel automatically positions an external modulating bypass damper or the non-calling modulating zone dampers based on which zones are calling, zone size and bypass damper size.

### On Panel Display

The 16x2 character, backlit display allows the setting of a wide range of options and provides real time monitoring of panel operation.

### Modulating Dampers

The damper uses a DC motor that provides twice the torque and 4 times the life of typical spring return dampers and uses only 2VA operating power.

# Pro221P Zoning Panel

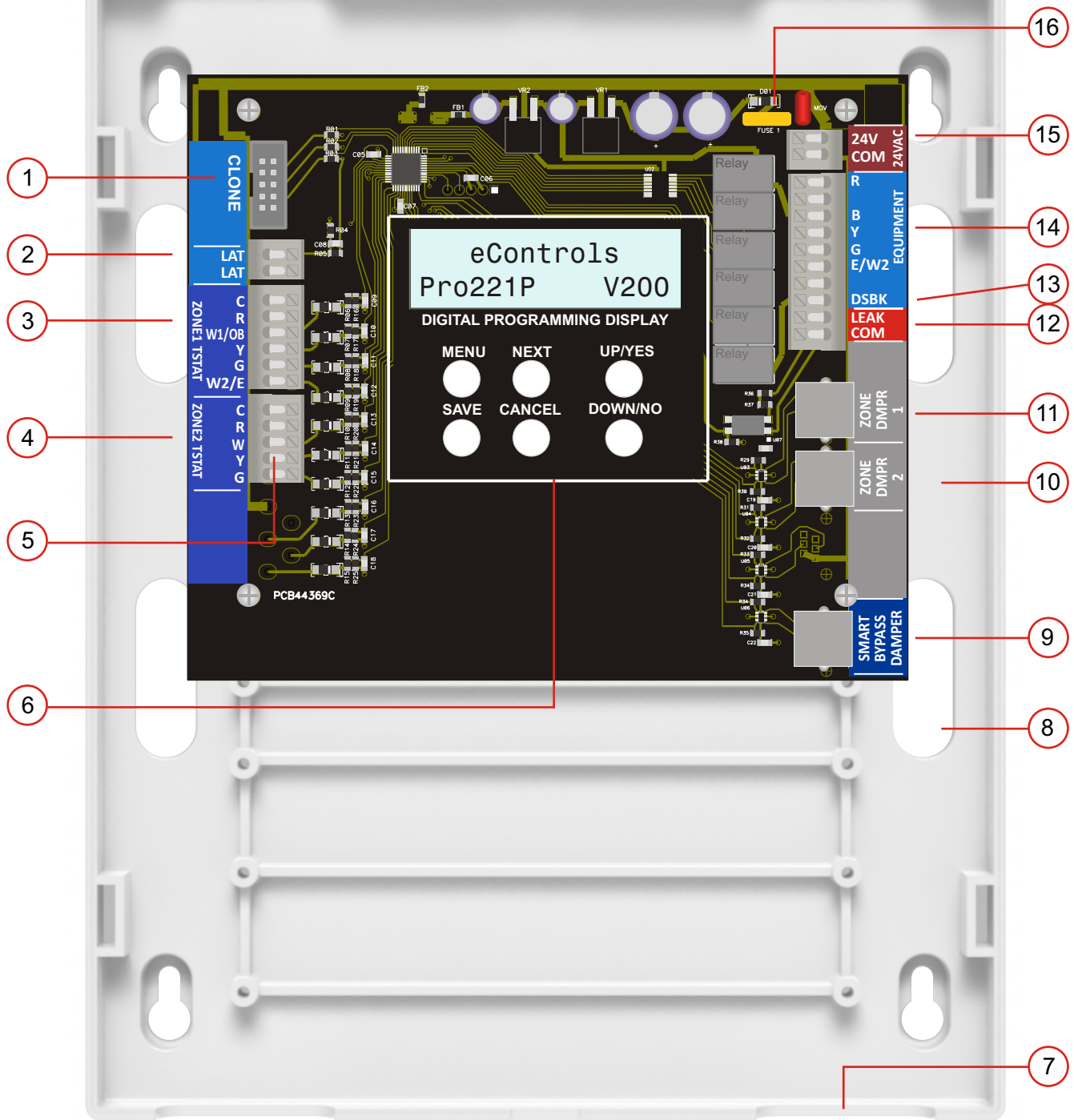

- |   |  |  |
|---|--|--|
| <p>① Connector for cloning panels with same options.</p> <p>② Terminals for Leaving Air Temperature sensor for downstaging when limits are exceeded.</p> <p>③ Terminals for Zone1 heat/cool or heat pump thermostat.</p> <p>④ Terminals for Zone2 heat/cool thermostat.</p> <p>⑤ Terminals are push in, screwless type for easy wiring.</p> | <p>⑥ On panel, backlit, 2x16 character LCD for intuitive programming of options and displaying panel status.</p> <p>⑦ Wiring access openings at top and bottom of case.</p> <p>⑧ Wiring access openings so wiring can be run behind case.</p> <p>⑨ Connector for external, modulating bypass damper controlled by panel.</p> <p>⑩ Large channels for wiring.</p> | <p>⑪ Connectors for plug&amp;play zone dampers.</p> <p>⑫ Terminals for equipment Leak Detection output– opens all dampers.</p> <p>⑬ DSBK terminal for operating fan in low speed when only one zone is calling.</p> <p>⑭ Terminals for heat pump equipment.</p> <p>⑮ Terminals for 24VAC, 40VA transformer.</p> <p>⑯ Automatic reset fuse.</p> |
|---|--|--|

## 1. 24VAC Power

A 40VA, 24VAC transformer can power the panel and up to 8 dampers and is connected as shown below.

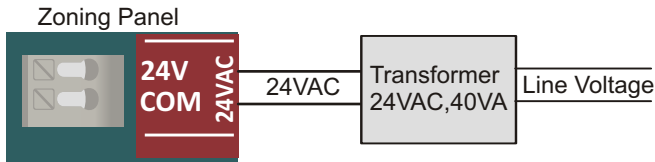

Shown below are typical power requirements for different zoning components.

Panel	10VA
Zone or Bypass Damper	2VA
Simple Zone Tstat	2VA
Smart, WiFi Zone Tstat	4.8VA

## 2. HVAC Equipment

The Pro221P is compatible with single compressor and single stage auxiliary heating. The wiring of heat pump with an O-type reversing valve is shown below.

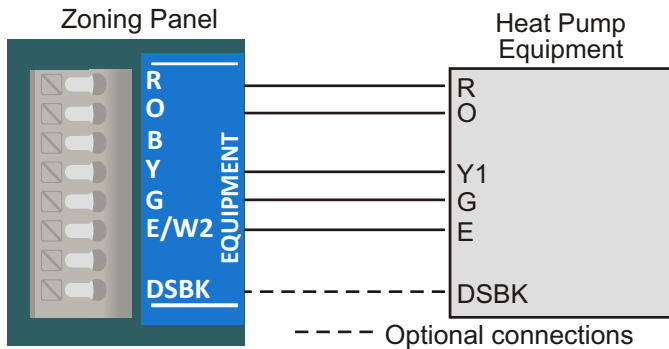

### DSBK Terminal

Some equipment have a DS, BK or HUM terminal that operates the fan in cooling at a lower speed to remove more humidity during cooling calls. This option can also be used to reduce the fan speed in cooling when only one zone is calling to reduce the amount of bypass. The DS function is activated when the panel applies 0VAC to the DS, BK or HUM equipment terminal.

### Electric Strip Heating Delay

A timer (10 to 240 minutes) can be set to delay the activation of the electric strip heating during calls to reduce energy consumption. Strip heating can only be activated if the panel has been continuously calling for heating equal to or longer than the Electric Strip Heating delay set by the installer.

## Emergency Heating

Emergency heating is used when the compressor heating has failed or not producing enough heat because of low outdoor temperatures. In emergency heating the compressors are turned off, the electric strip heating and the fan are activated. A heat pump thermostat should be used in Zone1 so Emergency heating can be controlled at the thermostat.

### A2L Refrigerant Leak Monitor

Equipment using A2L refrigerant have either a dedicated output that indicates when a leak has occurred or some equipment turn off 24VAC to the equipment R terminal when a leak occurs.

#### Equipment with a Dedicated Terminal

Connect the Dedicated terminal at the equipment to the LEAK terminal at the panel and connect the equipment C terminal to the COM terminal at the Panel that is next to LEAK.

#### Equipment Turn R Off

Connect the R terminal at the panel HVAC terminals to the LEAK terminal at the panel and connect the equipment C terminal to the COM terminal at the Panel that is next to LEAK.

## 3. Zone Thermostats

The Pro221P is compatible with any 24VAC powered Heat/Cool or Heat Pump Thermostat. A Heat Pump thermostat in Zone1 enables activation of Emergency heating. Use a Heat/Cool thermostat in Zone 2.

### Heat/Cool Tstat in Zone1

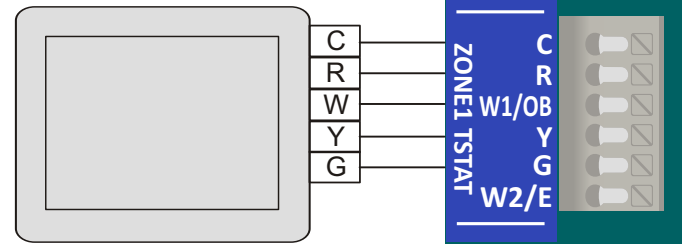

Heat pump installations should use a Heat Pump thermostat in Zone1 to enable activation of Emergency Heating.

### HeatPump Tstat in Zone1

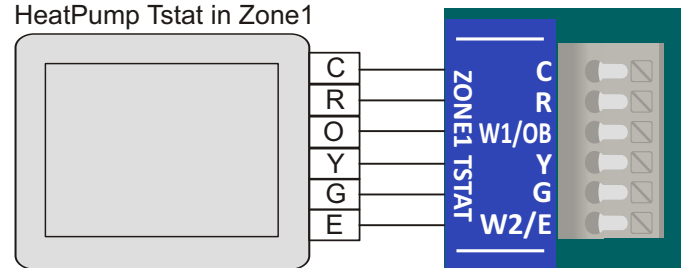

Use a heat/cool thermostat in Zone 2.

Heat/Cool Tstat in Zone2.

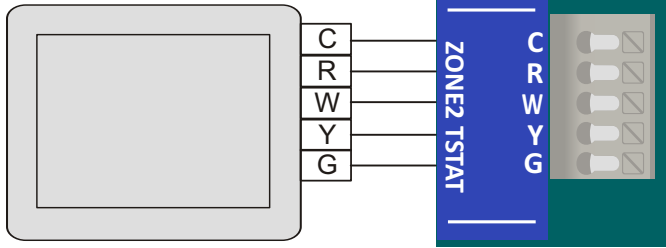

#### 4. Leaving Air Temperature Sensor

A Leaving Air Temperature Sensor is only required when an external bypass damper is used and dumps excess airflow into the return plenum. The TS2B Temperature Sensor is used to monitor the leaving air temperature. If the temperature exceeds the High Temp Limit, the panel will down-stage the equipment. If the panel is in a stage1 call, it will turn the heating or cooling call off and activate the fan.

#### 4. Leaving Air Temperature Sensor

In heating the panel will up-stage or restore the call when the leaving air temperature has dropped 20F or to 95F. In cooling the panel will up-stage or restore the call when the leaving air temperature has risen 10F or to 65F.

The TS2B sensor is installed in the leaving air or discharge air plenum so the 6-inch stainless steel tube is in the airflow.

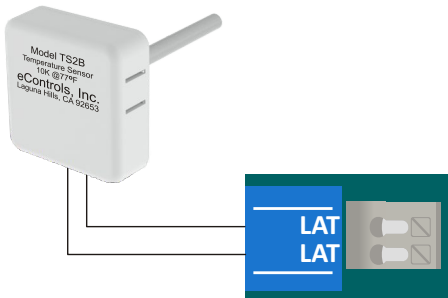

#### 5. Zone Dampers

The round zone dampers are available in 6 to 20-inch diameters and rectangular zone dampers are available in 8x8 inches to 16x20 inches. A modulating actuator is used and allows the dampers to be positioned anywhere from fully closed to fully open in as little as 2% increments when the non-calling zone dampers are used for bypass.

The actuators use a DC motor with about twice the torque of typical spring return actuators and yet only use 2VA when positioning and 1VA when holding position. The damper can fully open/close in about 3 seconds. The actuator uses electronic motor control for high reliability and long life. A 25-foot Plug&Play cable is supplied with each damper



R80ZJ-DD  
Modulating Damper

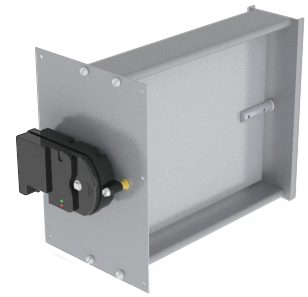

RT80ZJ-HHXDD  
Modulating Damper

Rectangular dampers require a cut in the duct 2-3/4 inches by the height of the duct. The damper slides into the opening and is secured with 6 sheet metal screws.

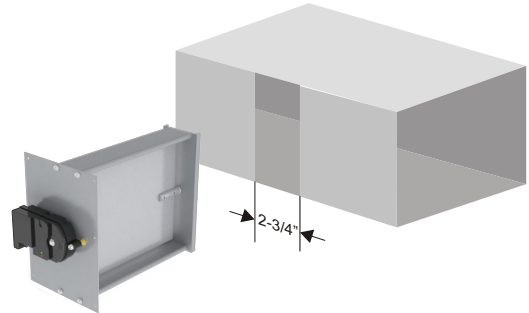

A 25-foot cable with 6-pin RJ11 connectors is provided with each damper. Plug the cable into the damper actuator IN connector and plug the other end into the corresponding connector on the panel. Plug&Play connection of the dampers to the panel is faster and eliminates wiring errors. Longer cables or extension Plug&Play cables are available.

If two or more dampers are required to define a zone, dampers can be daisy chained together by connecting the OUT connector on one damper to the IN connector on the second damper.

#### 6. Automatic Bypass Control

The installer can select bypassing using an external modulating damper automatically controlled by the zoning panel or using the non-calling zone dampers for bypass that are automatically controlled by the zoning panel.

##### External Bypass Damper

The external modulating bypass damper is automatically positioned by the panel to bypass the excess airflow to the return or a dump zone when one or more of the zones are not calling.

When External Bypass is selected, the panel calculates the minimum bypass damper size in CFM. Use your favorite conversion chart or the charts shown to convert the CFM to a damper size.

When calculating the bypass and the minimum bypass damper CFM, the panel uses the following.

- Total number of zones-- 2 or 3.
- Number of zones calling.
- Size of the bypass damper in cfm.
- Fan speed reduction in heating, typically 80% of cooling.
- Fan speed in cooling if DSBK is active, typically 80%.
- Maximum allowable CFM delivered to calling zones during bypass-- typically 150% of rated CFM.

When different zone sizes are used or options changed, use the display and select Change Bypass Options.

### Non-Calling Zone Bypass

The non-calling modulating zone dampers are automatically positioned by the panel to bypass the excess airflow and eliminate having to install an external bypass and discharge air temperature sensor.

There are some limitations to using Non-Calling Zone bypass. If the zones are different in size and one zone is small and is the only zone calling, the airflow through the non-calling zones can be large and degrade the benefits of zoning. This can be particularly apparent in 3-zone installations using non-calling dampers for bypass

The total CFM to be bypassed using the non-calling zone dampers is calculated the same as when using external bypass.

### About the LCD Display and Keys

The LCD display shown below is a typical screen when changing an option.

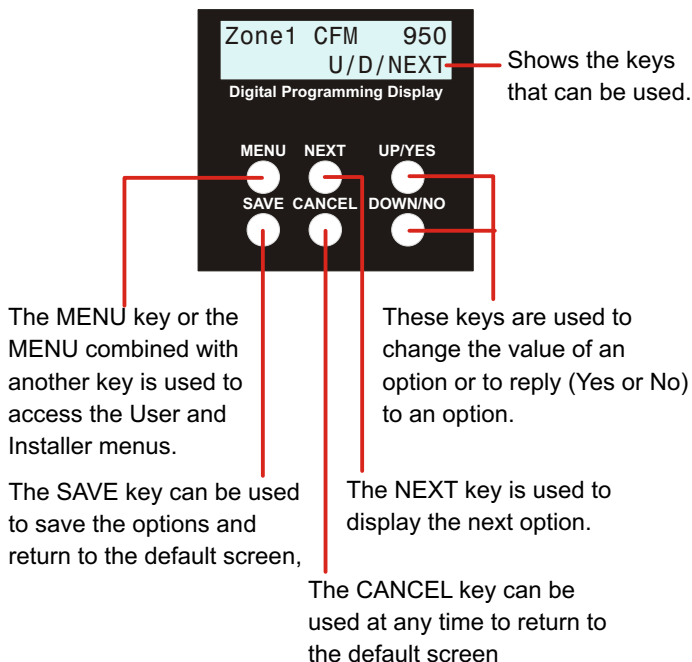

### User Menu

Press MENU to display the equipment call status and use NEXT to display the zone thermostat call status, zone damper positions and the bypass damper position if used.

### Installer Menu

Press MENU+UP to access the Installer options. The display will prompt the installer through the available options.

### Cloning a Panel

Press MENU+DOWN to access the cloning Menu to copy the option selections in one panel into another panel.

### Factory Settings

The panel is shipped with the factory set options as shown below. Options in gray are not applicable.

Equipment	Default	Range
Equipment Type	HPO	HPO or HPB
Cooling Stages	1	1
Aux Heating Stages	1	0 or 1
Aux Heating Delay	120	10 to 240 minutes
Zone1 Tstat	GE	GE or HP

### A2L Leak Monitor

A2L Leak Monitor	No	Yes or No
A2L Active Input	24VAC	0 or 24VAC

### Leaving Air Limits

High Temp Limit	160F	110 to 170F
Low Temp Limit	40F	32 to 50F

### Bypass Control

Bypass Type	Ext BP Damper	Non-calling zone dampers or ext bypass damper.
Zone1 CFM	800 cfm	200 to 1600 cfm
Zone2 CFM	800 cfm	200 to 1600 cfm
Heating CFM Percent	80%	70 to 100%
Over CFM Percent	50%	20 to 70%
Bypass Trim	100%	50 to 150%
Ext Bypass Damper	400 cfm	200 to 1600 cfm

### Timing Options

Minimum Off Time	3	0 to 9 minutes
Minimum Run Time	1	0 to 9 minutes

### Staging Options

Zones Calling	Yes	Yes or No
Stage2 Zones Calling	2	1 or 2
Staging Cont Call Time	Yes	Yes or No
Cont Call Time	20	5 to 60 minutes

## Advanced Options

Purge after Call	Yes	Yes or No
Purge Time	90	30 to 240 seconds
Fan in Purge	Yes	Yes or No
Dampers Open in Purge	All	All or last calling
Auto Changeover	No	Yes or No
Time to Auto Changeover	20	10 to 240 minutes
DSBK	No	Yes or No
DSBK Max Zones	1	1

## Customized Setup

This allows the installer to change any of the following options to customize the panel to most any equipment.

**Change Equipment Settings** Y/N Press YES key to select Changing Equipment settings or press NO to display the next option.

**Select Equip** HPO Y/N/NEXT Press NO key to select a Heat Pump with O-type reversing valve.

**Select Equip** HPB Y/N/NEXT Press YES to select a Heat Pump with B-type reversing valve.

## Heat Pump Selections

**Aux Heating Stages** 1 U/D/NEXT Use the UP/DOWN keys to select 0 or 1 auxiliary heating stages.

**Aux Heating Delay** 120 U/D/NEXT Use the UP/DOWN keys to change the auxiliary delay from 10 to 240 minutes to allow the compressor heating to satisfy the call. Press NEXT to continue.

**Zone1 Tstat** HP Y/N/NEXT Press YES key to select a heat pump thermostat in Zone1 to allow the control of Emergency heating.

**Zone1 Tstat** HC Y/N/NEXT Press NO key to display the next option.

Press NEXT key to select a heat-cool thermostat in Zone1.

## A2I Leak Monitor

**Change A2L Leak Monitor** Y/N Press YES key to enable the Leak Monitor or press NO for the next option.

**A2I Active 24VAC** Y/N/NEXT Press YES to select that 24VAC on the panel LEAK terminal indicates a refrigerant leak.

**A2I Active 0VAC** Y/N/NEXT Press NO to select that 0VAC on the panel LEAK terminal indicates a refrigerant leak.

Press NEXT to display the next option.

## Leaving Air Temperature Limits

**Change LAT Limit** 40/160F Y/N Press YES key to select changing the high or low leaving air temperature limits. Press NO for the next option

**High LAT Limit** 160F U/D/NEXT Press UP/DOWN keys to change the high temperature limit used in heating and then press NEXT.

**Low LAT Limit** 40F U/D/NEXT Press UP/DOWN keys to change the low temperature limit used in cooling and then press NEXT.

## Bypass Options

**Change Bypass Option** Y/N The Pro221PD automatically controls bypass using the non-calling modulating zone dampers or an external modulating bypass damper.

Press YES key to select changing the Bypass options or press NO for the next option.

**Non-Calling Zone Damper** Y/N/NEXT Press NO to select bypass using the non-calling zone damper.

**Ext Modulating Damper** Y/N/NEXT Press YES to select bypass using an external modulating bypass damper and then press NEXT.

**Zone1 CFM** 800 U/D/NEXT Set the CFM Demand of each zone using the UP/DOWN keys. The chart on the next page shows the relation between the damper size and CFM rating.

**Zone2 CFM** 800 U/D/NEXT

**Heating CFM** 80% U/D/NEXT In heating the fan generally runs at a lower speed and reduces the amount of bypass required. Press the UP/DOWN keys to change the percentage and then press NEXT.

**Max OverCFM Allowed** 150% U/D/NEXT Select the additional CFM that calling zones can accept without being noisy or annoying. Use the UP/DOWN keys to change the percentage and then press NEXT.

**BP Damper CFM** 400 U/D/NEXT The panel will calculate the CFM rating of the external bypass damper if used. If the CFM is between damper diameters, increase the CFM to the larger size. Use the UP/DOWN keys to set the damper CFM being used.

Press NEXT to display the next option.

Damper Diameter inches	Design Airflow cfm
6	85
7	125
8	180
9	240
10	325
12	525
14	750
16	1200
18	1500
20	2000

Design cfm for round dampers.

Design cfm for rectangular dampers.

		DEPTH						
		8	10	12	14	16	18	20
HEIGHT - ACTUATOR FACE	8	RT80ZJ-08x08 230 cfm	RT80ZJ-08x10 310 cfm	RT80ZJ-08x12 400 cfm	RT80ZJ-08x14 490 cfm	RT80ZJ-08x16 580 cfm	RT80ZJ-08x18 670 cfm	RT80ZJ-08x20 750 cfm
	10	RT80ZJ-10x08 310 cfm	RT80ZJ-10x10 430 cfm	RT80ZJ-10x12 550 cfm	RT80ZJ-10x14 670 cfm	RT80ZJ-10x16 800 cfm	RT80ZJ-10x18 930 cfm	RT80ZJ-10x20 1060 cfm
	12	RT80ZJ-12x08 400 cfm	RT80ZJ-12x10 550 cfm	RT80ZJ-12x12 680 cfm	RT80ZJ-12x14 800 cfm	RT80ZJ-12x16 950 cfm	RT80ZJ-12x18 1100 cfm	RT80ZJ-12x20 1250 cfm
	14	RT80ZJ-14x08 490 cfm	RT80ZJ-14x10 670 cfm	RT80ZJ-14x12 800 cfm	RT80ZJ-14x14 930 cfm	RT80ZJ-14x16 1060 cfm	RT80ZJ-14x18 1190 cfm	RT80ZJ-14x20 1320 cfm
	16	RT80ZJ-16x08 580 cfm	RT80ZJ-16x10 800 cfm	RT80ZJ-16x12 950 cfm	RT80ZJ-16x14 1060 cfm	RT80ZJ-16x16 1210 cfm	RT80ZJ-16x18 1360 cfm	RT80ZJ-16x20 1510 cfm
	18	RT80ZJ-18x08 670 cfm	RT80ZJ-18x10 930 cfm	RT80ZJ-18x12 1100 cfm	RT80ZJ-18x14 1190 cfm	RT80ZJ-18x16 1360 cfm	RT80ZJ-18x18 1530 cfm	
	20	RT80ZJ-20x08 750 cfm	RT80ZJ-20x10 1060 cfm	RT80ZJ-20x12 1250 cfm	RT80ZJ-20x14 1320 cfm	RT80ZJ-20x16 1510 cfm		

## Change Timing Options

**Change Timing Option** Y/N

Press YES key to change the timing options or press NO for the next option.

**Min Off Time 3 Minutes** U/D/NEXT

Use the UP/DOWN keys to set the minimum off time between calls and then press NEXT.

**Min Run Time 1 Minutes** U/D/NEXT

Use the UP/DOWN keys to set the minimum run time and then press NEXT for the next option.

## Staging Options

Staging from stage1 compressor heating to compressor heating and auxiliary heating is controlled by Auxiliary Heating Delay previously set.

## Advanced Options

**Change Advanced Option** Y/N

Press YES key to select changing the Advanced Options or press NO key to display the next option.

**Purge After Call** Yes Y/N/NEXT

Press YES key to select Purge. Purge turns the heating or cooling off at the end of a call and keeps the fan operating. Press NO to continue.

**Purge Time 90 Seconds** U/D/NEXT

Use the UP/DOWN keys to set the Purge time and then press NEXT.

**Fan In Purge** Yes Y/N/NEXT

Press YES key to select if the panel keeps the fan operating in purge and then press NEXT.

**Dampers In Purge** All Y/N/NEXT

Press DOWN key to select all dampers are open during Purge.

**Dampers In Last Purge** Y/N/NEXT

Or press UP key to select only the that only the dampers that were open when Purge started stay open during purge.

**Auto ChangeOver** Y/N

Press YES key to select the panel switching to the opposing system call after the panel has been calling for a number of minutes or press NO key for the next option.

**Min Run Time 20 Minutes** U/D/NEXT

Use the UP/DOWN keys to select the number of minutes the panel must be continuously calling before switching to the opposed system and then press NEXT.

**DSBK Option** Y/N

On Equipment with a DS, BK or HUM input, the DSBK option can be used to lower the fan speed in cooling to reduce bypass. Press YES key to the DSBK option or press NO to display the Save option.

**DSBK Max Zones 1** U/D/NEXT

Use the UP/DOWN keys to set the maximum zones calling for cooling to activate DSBK. Press NEXT to display the Save option.

## Save Options

**Save Options** Y/N

Press YES key to save the options previously set and return to the main display. Or press NO to return to normal operation.

# Status Display

To display the system status press the MENU key. One of the displays show below will be displayed. Typical Status displays are shown below.

Use the NEXT key to cycle through the system status, zone thermostat status, zone damper status and the external bypass damper if used. Press CANCEL to exit.

<b>Status</b> LAT 74	<b>Off</b> No calls active.
<b>Status Heating1</b> LAT 137	Calling for Stage1 Heating.
<b>Status Emergency</b> LAT 137 Heating	Calling for Emergency Heat.
<b>Status Cooling1</b> LAT 137	Calling for Stage1 Cooling.
<b>Status Heating</b> LAT 137 Purge	In Heating Purge cycle.

Press Next to display zone thermostat status.

<b>T1-Htg</b> T3=Off	<b>T2-Htg</b>	Zone3 is displayed if used. Press Next to display damper status.
<b>D1-Opn</b> D3=17%	<b>D2-Opn</b>	Damper display when bypassing using non-calling zone dampers. The percent shown is amount the damper is open and bypassing. Press Next to return to the System Status display.

<b>D1-Opn</b> D3=C1s	<b>D2-Opn</b>	Damper display when external bypass damper is used. Press Next to display external bypass damper status.
-------------------------	---------------	--

<b>Bypass Damper</b>	<b>47%</b> <b>180 cfm</b>	Percent indicates how much the damper is open. Press Next to return to the System Status display.
<b>Bypass Damper</b>	<b>Closed</b> <b>0 cfm</b>	

## Cloning Panels

The option settings of one panel can be easily copied into multiple panels. This insures all the panels for a given home model operate the same.

Connect the two panels using the ribbon cable (PN 44395), Conect the panel containing the options to be copied to 24VAC. The panel is ready to be cloned.

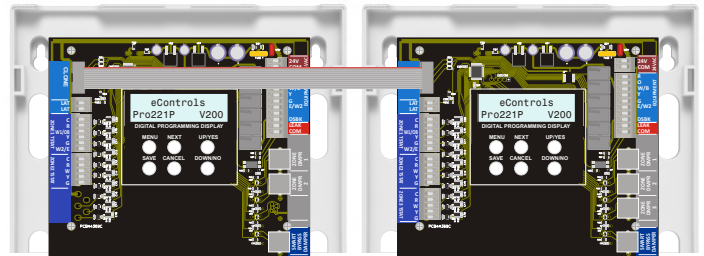

New Panel to be Cloned

Original Zoning Panel

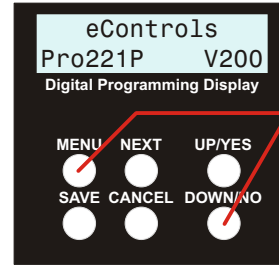

Press both keys.

On the new panel to be cloned, press MENU and DOWN keys.

<b>Clone Panel</b>	<b>New</b> Y/N/NEXT
--------------------	------------------------

Press the UP key to set the new panel to New and press NEXT.

<b>Waiting For Data</b>	<b>CANCEL</b>
-------------------------	---------------

The message Waiting for Data is displayed. To terminate cloning press the CANCEL key.

<b>Cloning Done</b>	<b>CANCEL</b>
---------------------	---------------

The message Cloning Done is displayed. To return to normal operation press the CANCEL key.

On the original panel containing the options to be cloned, press MENU and DOWN keys.

<b>Clone Panel</b>	<b>Original</b> Y/N/NEXT
--------------------	-----------------------------

Press the DOWN key to set the panel to Original and press NEXT.

<b>Sending Data</b>	<b>CANCEL</b>
---------------------	---------------

The message Sending Data is displayed. To terminate cloning press the CANCEL key.

<b>Cloning Done</b>	<b>CANCEL</b>
---------------------	---------------

The message Cloning Done is displayed. To return to normal operation press the CANCEL key.



eControls, Inc.  
26072 Merit Circle #110 / Laguna Hills, CA 92653  
949-916-0945 Fax 949-458-8502 www.eControlsUSA.com